



IAM Amplifiers

Small In-line Modules - Fixed or Unregulated Excitation

IAM Amplifier for Fixed Excitation

-WW Model

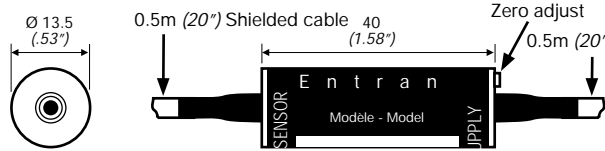

-1W Model



Dim : mm (inches)

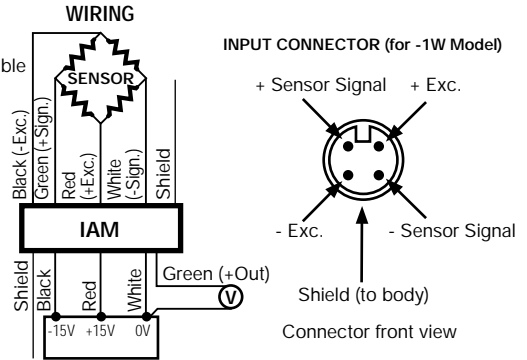

Amplifier Performance

GAIN (G) ±5%:	1, 10, 20, 50, 100, 200, 500 or 1000
BANDWIDTH (-3dB) nom.:	100KHz
SLEW RATE:	4V/μs
POWER REQUIRED:	15 = ±15VDC
OUTPUT SIGNAL:	±12V max.
OUTPUT CURRENT max.:	5mA
INPUT IMPEDANCE nom.:	1GΩ
OUTPUT IMPEDANCE nom.:	1Ω
BASE LINE (NULL) ADJUSTABILITY:	±5V
NON-LINEARITY:	0.1% max.

Supply For Sensors, General Characteristics, Options & Accessories

SENSOR SUPPLY VOLTAGE:	05 = 5V 10 = 10V 15 = 15V
SENSOR SUPPLY CURRENT max.:	15mA
COMMON MODE REJECTION:	100dB typ. @ G= 100 to 1000
INPUT PROTECTION:	Reverse Polarity Protected
OUTPUT PROTECTION:	Short Circuit Protected
CE CONFORMANCE:	EN61010-1, EN 50081-1, EN 50082-1
OPERATING TEMPERATURE:	-20°C to 70°C (-4°F to 158°F)
STORAGE TEMPERATURE:	-55°C to 125°C (-67°F to 257°F)
WIRING:	WW = Shielded cable input and output 1W = Male connector on Input Side, type EM4 with unwired mate (will <u>not</u> mate with Option C connector), shielded cable on Output Side
SPECIAL OUTPUT CABLE LENGTH:	L00F = Replace "00" with total length in feet. L00M = Replace "00" with total length in meters.
CONNECTOR WIRED TO OUTPUT CABLE:	C = Microtech type male or equivalent on Output Side only (w/o mate), style EC-CM4 RS = RJ Telephone type male (w/o mate) WI = Wire to sensor
WIRE AMPLIFIER INPUT TO A SENSOR:	

Model Number construction

IAM Series	-	15 Power Required	/05 Sensor Supply Voltage	/500 Gain	-	W W (IN) (OUT) Cable or Connector	-	/WI/L3M/C Options
		15	05 10 15	1 10 20 50		100 200 500 1000		C or RS L00F or L00M WI

 www.entran.com	IAM AMPLIFIERS Small In-line Modules		Entran Sensors & Electronics USA: Fairfield, NJ UK: Garston, Watford, Herts, England Europe: Les Clayes-sous-Bois, France		
	SPECIFICATION		ISSUE	PAGE	
	IAMS0001U		PBO	1 of 2	

IAMR specifications continued ...

IAMR Amplifier with Voltage Regulator for Unregulated Excitation

-WW Model

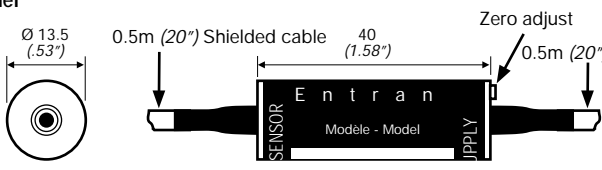

-1W Model

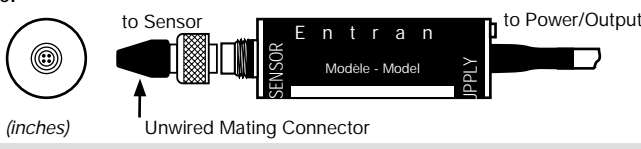

Dim : mm (inches)

Unwired Mating Connector

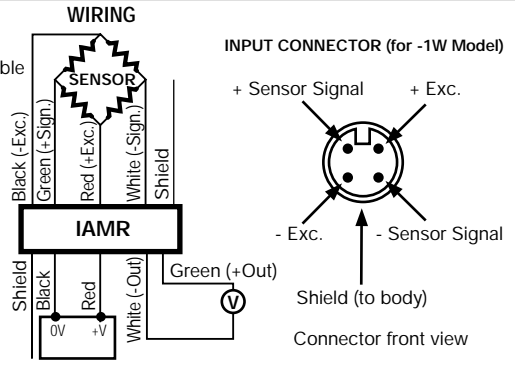

Amplifier Performance

GAIN (G) ±5%:	10, 20, 50, 100, 200 or 500
BANDWIDTH (-3dB) nom.:	700KHz/G (70KHz @ G = 10, 1.4KHz @ G = 500)
SLEW RATE:	1V/μs
POWER REQUIRED:	12U = 10V to 14V Unregulated 28U = 24V to 32V Unregulated
OUTPUT SIGNAL max.:	For Power Type 12U : ±2V (Common Mode Voltage +2.5V) For Power Type 28U : ±4V (Common Mode Voltage +5V)
OUTPUT CURRENT max.:	5mA
INPUT IMPEDANCE nom.:	10MΩ
OUTPUT IMPEDANCE nom.:	1KΩ
BASE LINE (NULL) ADJUSTABILITY:	For Power Type 12U : ±0.7V For Power Type 28U : ±1.4V
NON-LINEARITY:	0.1% max.

Supply For Sensors, General Characteristics, Options & Accessories

SENSOR SUPPLY VOLTAGE:	05 =5V for Power type 12U 05 =5V or 10 =10V for Power type 28U
SENSOR SUPPLY CURRENT max.:	15mA
COMMON MODE REJECTION:	85dB @ G = 10 115dB @ G = 500
INPUT PROTECTION:	Reverse Polarity Protected
OUTPUT PROTECTION:	Short Circuit Protected
CE CONFORMANCE:	EN61010-1, EN 50081-1, EN 50082-1
OPERATING TEMPERATURE:	-20°C to 70°C (-4°F to 158°F)
STORAGE TEMPERATURE:	-55°C to 125°C (-67°F to 257°F)
WIRING:	WW = Shielded cable input and output 1W = Male connector on Input Side, type EM4 with unwired mate (will <u>not</u> mate with Option C connector), shielded cable on Output Side
SPECIAL OUTPUT CABLE LENGTH:	L00F = Replace "00" with total length in feet. L00M = Replace "00" with total length in meters.
CONNECTOR WIRED TO OUTPUT CABLE:	C = Microtech type male or equivalent on Output Side only (w/o mate), style EC-CM4 RS = RJ Telephone type male (w/o mate) WI = Wire to sensor
WIRE AMPLIFIER INPUT TO A SENSOR:	

Model Number construction

<u>IAMR</u> Series	-	<u>28U</u> Power Required	<u>/05</u> Sensor Supply Voltage	<u>/500</u> Gain	-	<u>W</u> <u>W</u> (IN) (OUT) Cable or Connector	-	<u>/WI/L3M/C</u> Options
		12U	05	10		WW		C or RS
		28U	05 or 10	20		1W		L00F or L00M
				50				WI
				100				
				200				
				500				

<h1>Entran®</h1>	<h2>IAM AMPLIFIERS</h2>	SPECIFICATION	ISSUE	PAGE
		IAMS0001U	PB0	2 of 2